

DropsA

Lubrication Systems Specialists

PPO RANGE PNEUMATIC OIL PUMPS FOR OIL AND SIMILAR FLUIDS 1-5

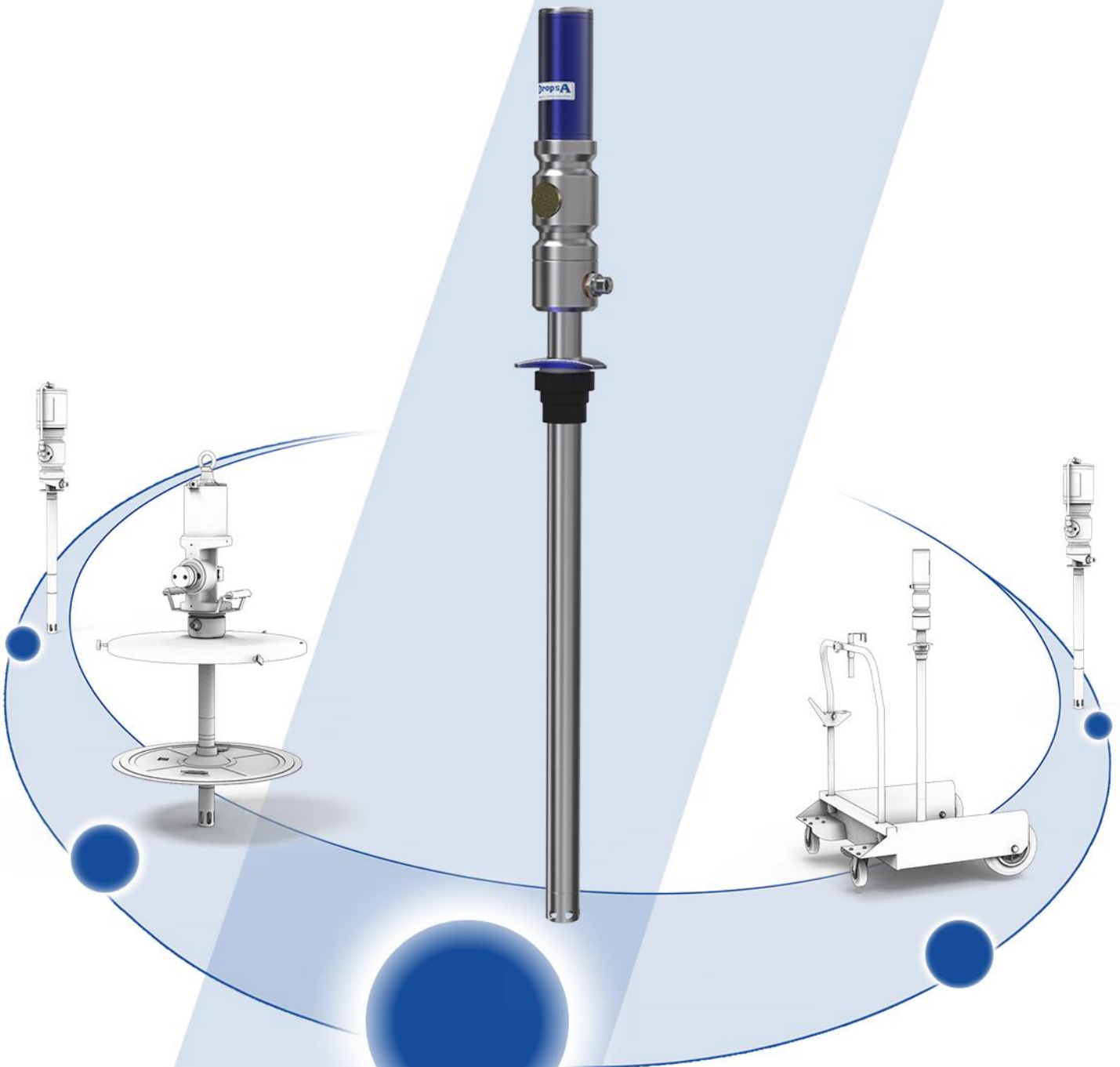

BARRELPUMP.IR

dropsa.com

FEATURES

- Air-operated oil pump R = 1:1
- Working pressure: 6-8 bar
- Standard drums of 180–220 l (shank length 940 mm)
- Standard tanks of 750–1500 (shank length 1250 mm)
- Polyurethane seals
- With threaded ring for drum connection

PPO PNEUMATIC OIL PUMPS R = 1:1 DELIVERY = 40 l/min

These pumps are advised for the transfer of low viscosity oil (SAE 15/80), hydraulic oil, similar fluids and antifreeze, for short distances (5 – 10 m).

The delivery capacity of a pump varies according to particular applications and combinations: the pressure of air supplied; viscosity and temperature of the fluid; dimensions of delivery hose; dimensions of connections and type of gun which is used. The operating pressure may vary between a minimum of 3 bar and a maximum of 8 bar.

To optimize the performance and the time-life of the air-operated pumps we advise to use filtered and lubricated air.

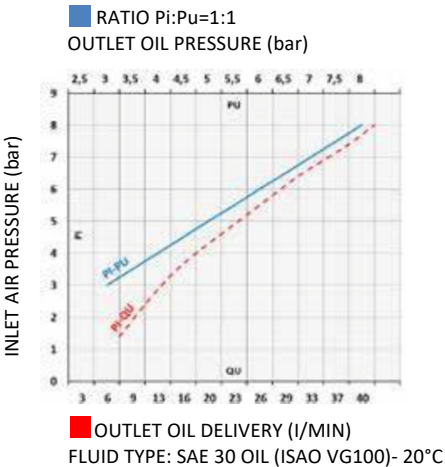
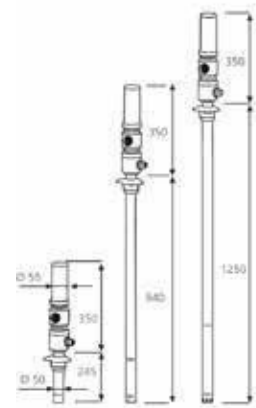
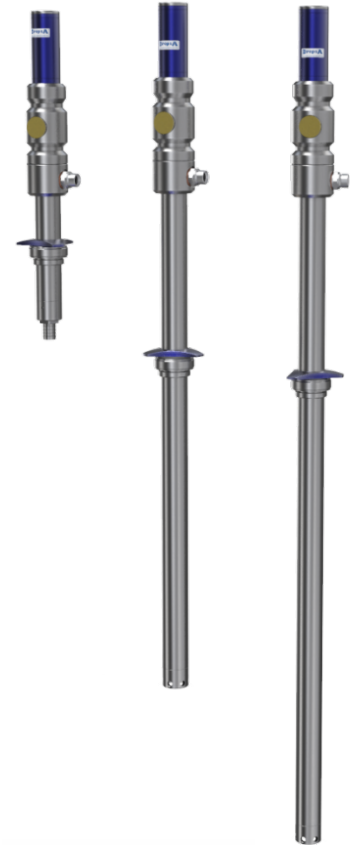

- 1*
- 2*
- 3*

GENERAL TECHNICAL FEATURES				
Part Number		0234827 (1*)	0234828 (2*)	0234829 (3*)
Compression ratio	bar	1:1	1:1	1:1
Max air pressure	bar	8	8	8
Max outlet pressure	bar	8	8	8
Air consumption	l/m	220	220	220
Air inlet connection	BSP	F 1/4" G	F 1/4" G	F 1/4" G
Oil outlet connection	BSP	M 3/4" G	M 3/4" G	M 3/4" G
Oil delivery @8 bar	l/m	40	40	40
Noise	dB	80	80	80
Shank diameter	mm	50	50	50
Shank length	mm	245	940	1250
For drums with capacity of l		-	180-220	750-1500

FEATURES

- Double-acting air-operated oil pump
R = 3:1
- Working pressure: 3-8 bar
- Standard drums of 50-60 l
(shank length 740 mm)
- Standard drums of 180-220 l
(shank length 940 mm)
- Standard tanks of 750-1500 l
(shank length 1250 mm)
- Polyurethane seals
- With threaded ring for drum connection

PPO PNEUMATIC OIL PUMPS
R = 3:1 DELIVERY = 30 l/min

These pumps are advised for the transfer of low - medium viscosity oil (SAE 15/130), and anti-freeze, for short-medium distances (40 - 50 m).

The delivery capacity of a pump varies according to particular applications and combinations: the pressure of air supplied; viscosity and temperature of the fluid; dimensions of delivery hose; dimensions of connections and type of gun which is used. The operating pressure may vary between a minimum of 3 bar and a maximum of 8 bar.

The double-acting guarantees the delivery of a continuous and constant flow, suitable for installations on distribution facilities. To optimize the performance and the time-life of the air-operated pumps we advise to use filtered and lubricated air.



■ RATIO $P_i:P_u=1:1$
 OUTLET OIL PRESSURE (bar)

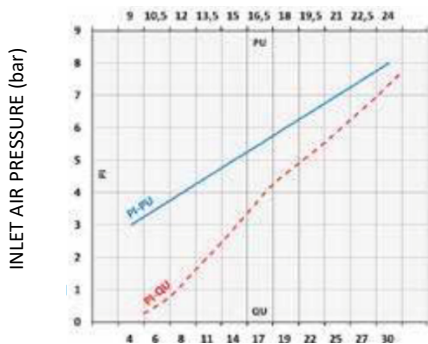

■ OUTLET OIL DELIVERY (l/MIN)
 FLUID TYPE: SAE 30 OIL (ISAO VG100)- 20°C

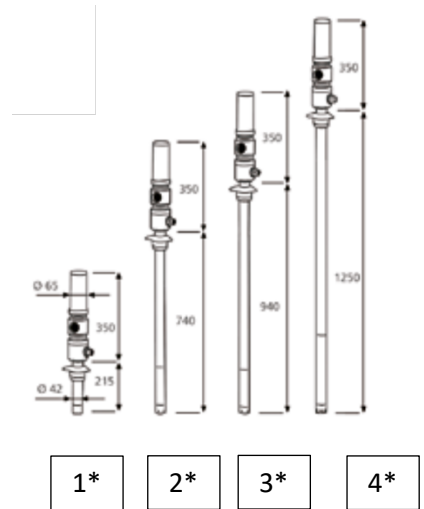

GENERAL TECHNICAL FEATURES					
Part Number		0400737 (1*)	0234832 (2*)	0400738 (3*)	0400739 (4*)
Compression ratio		3:1	3:1	3:1	3:1
Max air pressure	bar	8	8	8	8
Max outlet pressure	bar	24	24	24	24
Air consumption	l/min	220	220	220	220
Air inlet connection	BSP	F 1/4" G	F 1/4" G	F 1/4" G	F 1/4" G
Oil outlet connection	BSP	M 1/2" G	M 1/2" G	M 1/2" G	M 1/2" G
Oil delivery @8 bar	l/min	30	30	30	30
Noise	dB	80	80	80	80
Shank diameter	mm	42	42	42	42
Shank length	mm	215	740	940	1250
For drums with capacity of	l	-	50-60	180-220	750-1500

FEATURES

- Double-acting air-operated oil pump
R = 3:1
- Working pressure: 6-8 bar
- Standard drums of 180-220 l
(shank length 940 mm)
- Standard tanks of 750-1500 l
(shank length 1250 mm)
- Polyurethane seals
- With threaded ring for drum connection
- Suitable for workshops oil distribution applications for industrial vehicles in which it is requested a high delivery with more dispensing points

PPO PNEUMATIC OIL PUMPS

R = 3:1 DELIVERY = 40 l/min

These pumps are advised for the transfer of low-medium viscosity oil (SAE 15/130), and anti-freeze, for short-medium distances (40 - 50 m).

The delivery capacity of a pump varies according to particular applications and combinations: the pressure of air supplied; viscosity and temperature of the fluid; dimensions of delivery hose; dimensions of connections and type of gun which is used.

The operating pressure may vary between a minimum of 3 bar and a maximum of 8 bar.

The double-acting guarantees the delivery of a continuous and constant flow, suitable for installations on distribution facilities. To optimize the performance and the time-life of the air-operated pumps, we advise to use filtered and lubricated air.

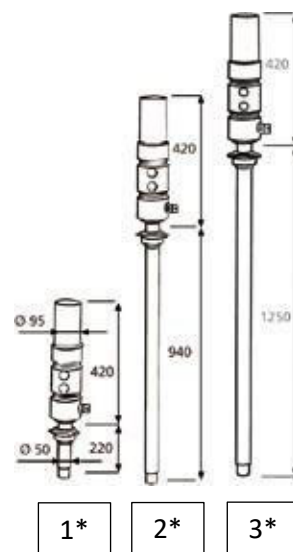
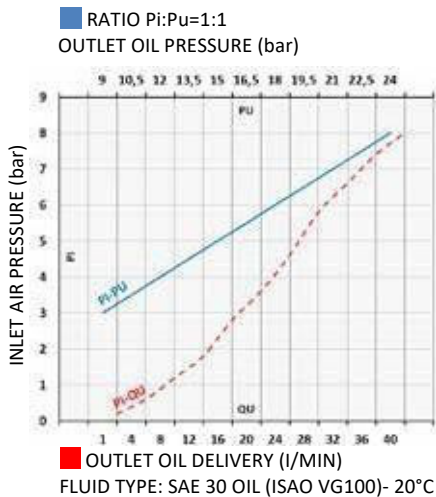

GENERAL TECHNICAL FEATURES				
Part Number		0400733 (1*)	0234830 (2*)	0400734 (3*)
Compression ratio		3:1	3:1	3:1
Max air pressure	bar	8	8	8
Max outlet pressure	bar	24	24	24
Air consumption	l/min	340	340	340
Air inlet connection	BSP	F 3/8" G	F 3/8" G	F 3/8" G
Oil outlet connection	BSP	M 3/4" G	M 3/4" G	M 3/4" G
Oil delivery @8 bar	l/min	40	40	40
Noise	dB	80	80	80
Shank diameter	mm	50	50	50
Shank length	mm	220	940	1250
For drums with capacity of	l	-	180-220	750-1500

BARRELPUMPIR

PPO PNEUMATIC AIR-OPERATED OIL PUMPS

R=5:1 DELIVERY= 28 l/min FOR OIL AND SIMILAR FLUIDS



FEATURES

- Double-acting air-operated oil pump
R = 5:1
- Working pressure: 6-8 bar
- Standard drums of 50-60 l
(shank length 740 mm)
- Standard drums of 180-220 l
(shank length 940 mm)
- Standard tanks of 750-1500 l
(shank length 1250 mm)
- Polyurethane seals
- With threaded ring for drum connection

PPO PNEUMATIC OIL PUMPS

R = 5:1 DELIVERY = 28 l/min

These pumps are advised for the transfer of medium-high viscosity oil (SAE 15/240), and anti-freeze, for medium-long distances (150 - 200 m).

The delivery capacity of a pump varies according to particular applications and combinations: the pressure of air supplied; viscosity and temperature of the fluid; dimensions of delivery hose; dimensions of connections and type of gun which is used.

The operating pressure may vary between a minimum of 3 bar and a maximum of 8 bar.

The double-acting guarantees the delivery of a continuous and constant flow, suitable for installations on distribution facilities. To optimize the performance and the time-life of the air-operated pumps, we advise to use filtered and lubricated air.

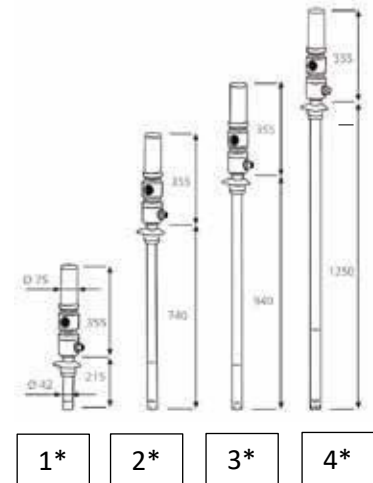
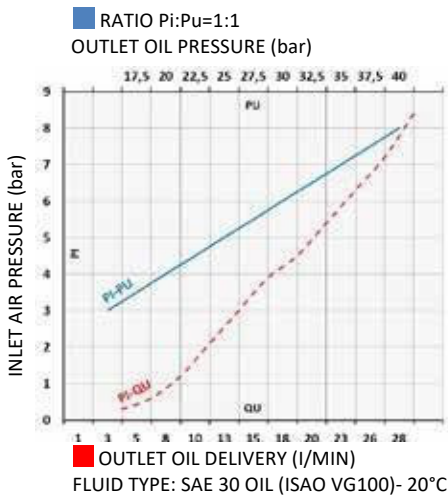

1* 2* 3* 4*

GENERAL TECHNICAL FEATURES					
Part Number		0400740 (1*)	0234833 (2*)	0400741 (3*)	0400742 (4*)
Compression ratio		5:1	5:1	5:1	5:1
Max air pressure	bar	8	8	8	8
Max outlet pressure	bar	40	40	40	40
Air consumption	l/min	250	250	250	250
Air inlet connection	BSP	F 1/4" G	F 1/4" G	F 1/4" G	F 1/4" G
Oil outlet connection	BSP	M 1/2" G	M 1/2" G	M 1/2" G	M 1/2" G
Oil delivery @8 bar	l/min	28	28	28	28
Noise	dB	80	80	80	80
Shank diameter	mm	42	42	42	42
Shank length	mm	215	740	940	1250
For drums with capacity of	l	-	50-60	180-220	750-1500

FEATURES

- Double-acting air-operated oil pump
R = 5:1
- Working pressure: 6-8 bar
- Standard drums of 180-220 l (shank length 940 mm)
- Standard tanks of 750-1500 l (shank length 1250 mm)
- With threaded ring for drum connection
- Suitable for workshops oil distribution applications for industrial vehicles in which it is requested a high delivery with more dispensing points

PPO PNEUMATIC OIL PUMPS

R = 5:1 DELIVERY = 35 l/min

These pumps are advised for the transfer of medium-high viscosity oil (SAE 15/240), and anti-freeze, for medium-long distances (150 - 200 m).

The delivery capacity of a pump varies according to particular applications and combinations: the pressure of air supplied; viscosity and temperature of the fluid; dimensions of delivery hose; dimensions of connections and type of gun which is used. The operating pressure may vary between a minimum of 3 bar and a maximum of 8 bar.

The double-acting guarantees the delivery of a continuous and constant flow, suitable for installations on distribution facilities. To optimize the performance and the time-life of the air-operated pumps, we advise to use filtered and lubricated air.

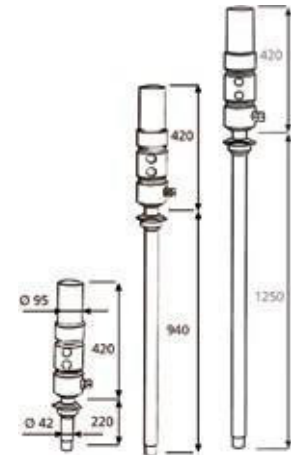
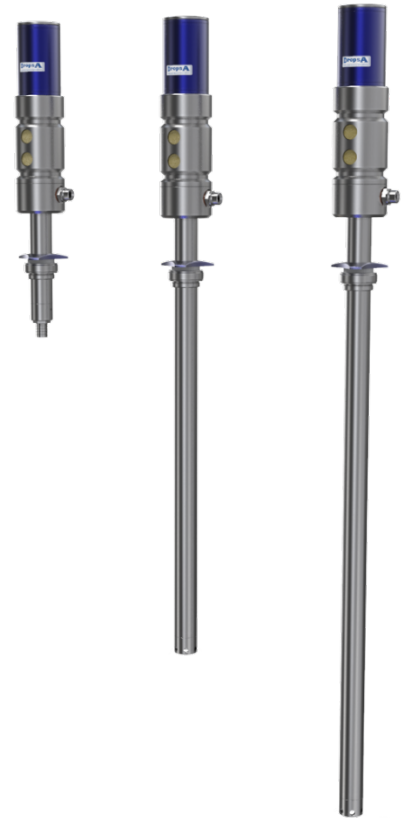

1* 2* 3*

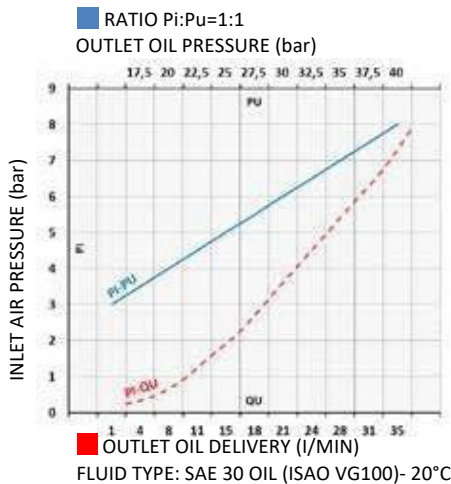

GENERAL TECHNICAL FEATURES

		0400735 (1*)	0234831 (2*)	0400736 (3*)
Part Number		0400735 (1*)	0234831 (2*)	0400736 (3*)
Compression ratio		5:1	5:1	5:1
Max air pressure	Bar	8	8	8
Max outlet pressure	Bar	40	40	40
Air consumption	l/min	385	385	385
Air inlet connection	BSP	F 3/8" G	F 3/8" G	F 3/8" G
Oil outlet connection	BSP	M 3/4" G	M 3/4" G	M 3/4" G
Oil delivery @8 bar	l/min	35	35	35
Noise	dB	80	80	80
Shank diameter	Mm	42	42	42
Shank length	Mm	220	940	1250
For drums with capacity of	L	-	180-220	750-1500

BARRELPUMP. IR