

DropsA

Lubrication Systems Specialists

IPO RANGE INDUSTRIAL OIL PUMPS FOR OIL AND SIMILAR FLUIDS 5-20

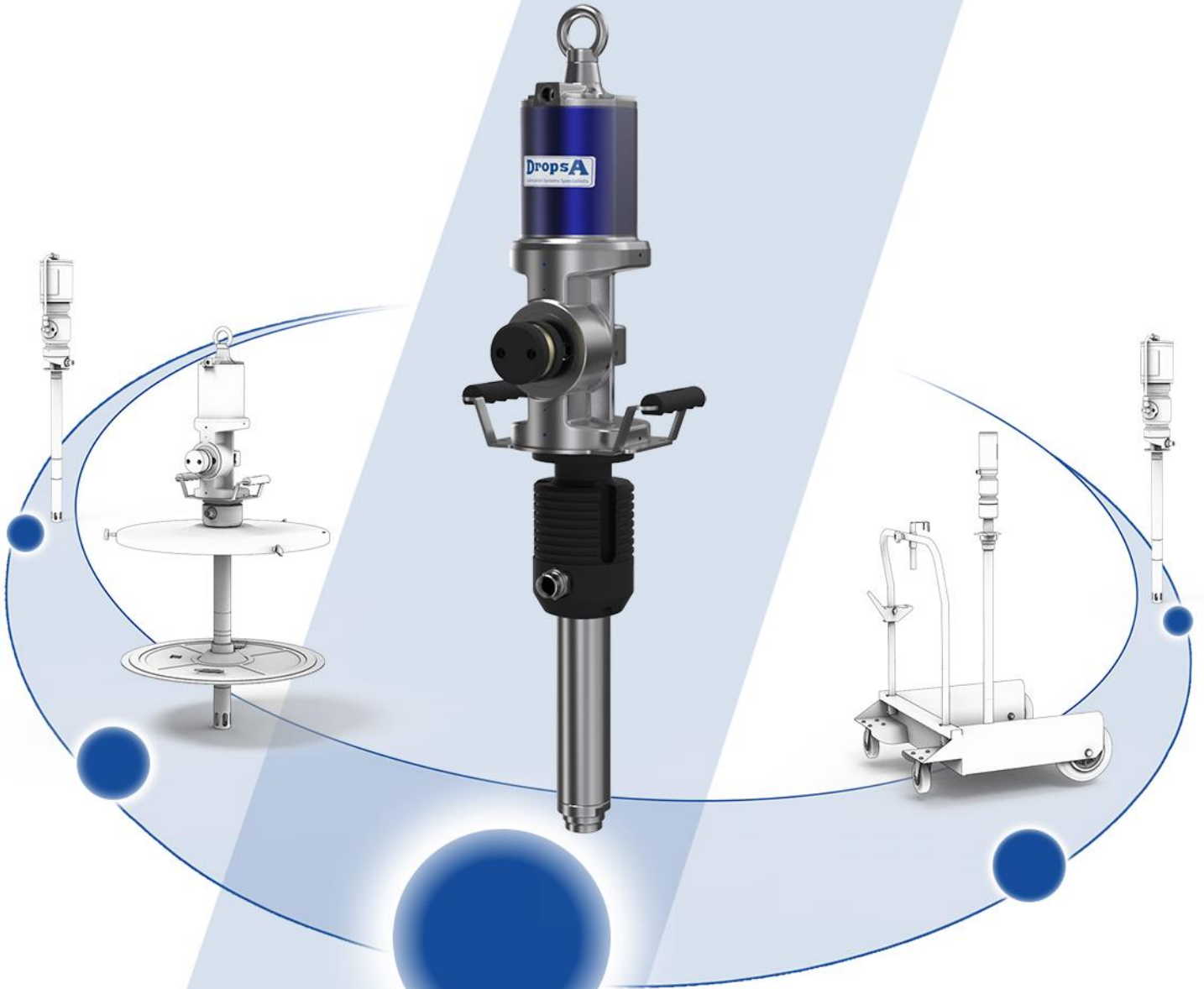

BARRELPUMP.IR

dropsa.com

IPO INDUSTRIAL AIR-OPERATED OIL PUMPS R = 5:1 FOR OIL AND SIMILAR FLUIDS



FEATURES

- Air-operated oil pump
- R = 5:1 Double-acting
- Working pressure: up to 8 bar
- For wall-fixing or fixed positions
- Polyurethane seals

IPO INDUSTRIAL OIL PUMPS R= 5:1 DELIVERY = 50 l/min

These pumps are advised for the transfer of low-high viscosity oil and similar fluids for medium-long distances. The delivery capacity of a pump varies according to particular applications and combinations. The operating pressure may vary between a minimum of 3 bar and a maximum of 8 bar.

The double-acting guarantees the delivery of a continuous and constant flow, suitable for installations on distribution facilities. To optimize the performance and the time-life of the air-operated pumps we advise to use filtered and lubricated air.

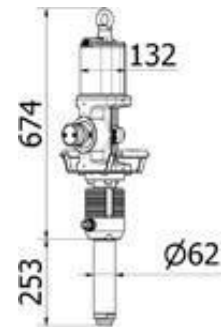
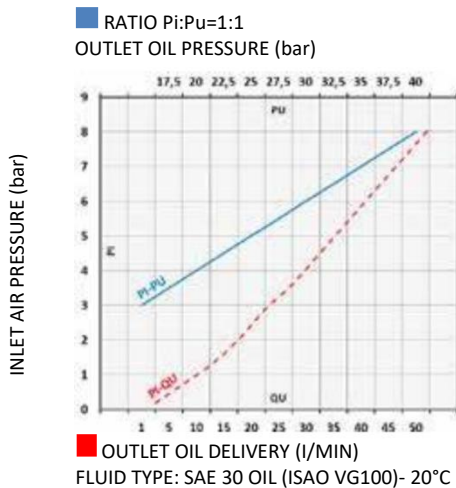

1*

GENERAL TECHNICAL FEATURES

GENERAL TECHNICAL FEATURES		
Part Number		0400743 (1*)
Compression ratio		5:1
Max air pressure	bar	8
Max outlet pressure	bar	40
Air consumption @8 bar	m ³ /min	1,75
Air inlet connection	BSP	F 1/2" G
Fluid outlet connection	BSP	M 3/4" G
Fluid delivery @8 bar	l/min	50
Noise	dB	80
Shank diameter	mm	62
Shank length	mm	Modular F1"

BARRELPUMP.IT

FEATURES

- Air-operated oil pump
- R = 8:1 Double-acting
- Working pressure: up to 8 bar
- For wall-fixing or fixed positions
- Polyurethane seals

IPO INDUSTRIAL OIL PUMPS R = 8:1 DELIVERY = 40 l/min

These pumps are advised for the transfer of low-high viscosity oil and similar fluids for medium-long distances. The delivery capacity of a pump varies according to particular applications and combinations. The operating pressure may vary between a minimum of 3 bar and a maximum of 8 bar.

The double-acting guarantees the delivery of a continuous and constant flow, suitable for installations on distribution facilities. To optimize the performance and the time-life of the air-operated pumps, we advise to use filtered and lubricated air.

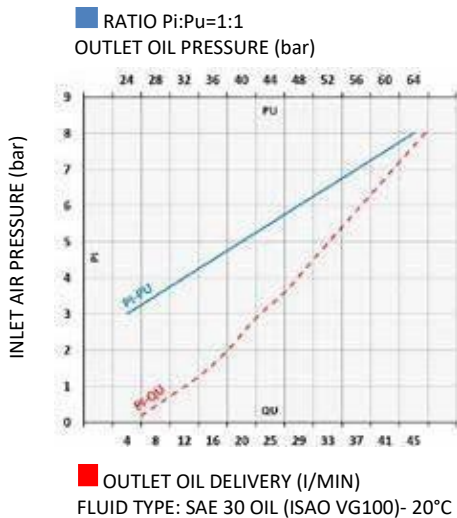
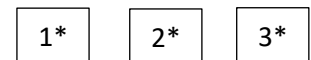

GENERAL TECHNICAL FEATURES				
Part Number		0400744 (1*)	0400745 (2*)	0400721 (3*)
Compression ratio		8:1	8:1	8:1
Max air pressure	bar	8	8	8
Max outlet pressure	bar	64	64	64
Air consumption @8 bar	m ³ /min	1,75	1,75	1,75
Air inlet connection	BSP	F 1/2" G	F 1/2" G	F 1/2" G
Fluid outlet connection	BSP	M 3/4" G	M 3/4" G	M 3/4" G
Fluid delivery @8 bar	l/min	40	40	40
Noise	dB	80	80	80
Shank diameter	mm	50	50	50
Shank length	mm	Modular F 1"	940	1250
For drums	l	-	180-220	750-1500

FEATURES

- Air-operated oil pump
- R = 10:1 Double-acting
- Working pressure: up to 8 bar
- For wall-fixing or fixed positions
- Polyurethane seals

**IPO INDUSTRIAL OIL PUMPS
R = 10:1 DELIVERY = 35 l/min**

These pumps are advised for the transfer of low-high viscosity oil and similar fluids for medium-long distances. The delivery capacity of a pump varies according to particular applications and combinations. The operating pressure may vary between a minimum of 3 bar and a maximum of 8 bar.

The double-acting guarantees the delivery of a continuous and constant flow, suitable for installations on distribution facilities. To optimize the performance and the time-life of the air-operated pumps, we advise to use filtered and lubricated air.

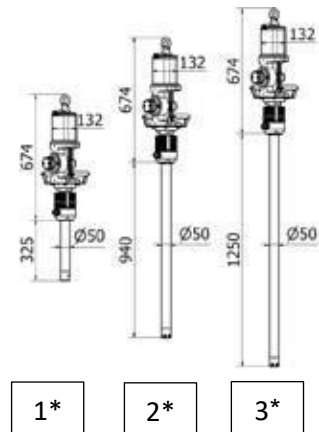
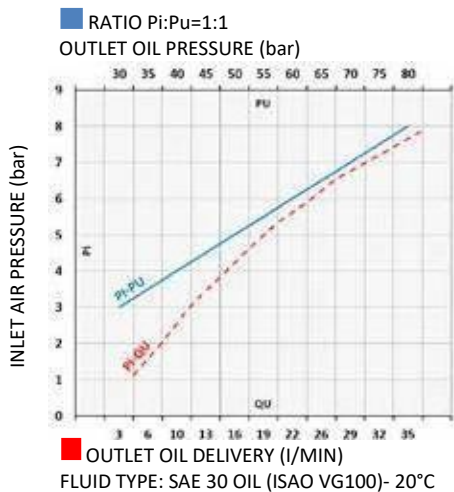

GENERAL TECHNICAL FEATURES				
Part Number		0400722 (1*)	0400746 (2*)	0400723 (3*)
Compression ratio		10:1	10:1	10:1
Max air pressure	bar	8	8	8
Max outlet pressure	bar	80	80	80
Air consumption @8 bar	m ³ /min	1,75	1,75	1,75
Air inlet connection	BSP	F 1/2" G	F 1/2" G	F 1/2" G
Fluid outlet connection	BSP	M 3/4" G	M 3/4" G	M 3/4" G
Fluid delivery @8 bar	l/min	35	35	35
Noise	dB	80	80	80
Shank diameter	mm	50	50	50
Shank length	mm	Modular F 1"	940	1250
For drums	l		180-220	750-1500

FEATURES

- Air-operated oil pump
- R = 18:1 Double-acting
- Working pressure: up to 8 bar
- For wall-fixing or fixed positions
- Polyurethane seals

**IPO INDUSTRIAL OIL PUMPS
R = 18:1 DELIVERY = 25 l/min**

These pumps are advised for the transfer of low-high viscosity oil and similar fluids for medium-long distances. The delivery capacity of a pump varies according to particular applications and combinations. The operating pressure may vary between a minimum of 3 bar and a maximum of 8 bar.

The double-acting guarantees the delivery of a continuous and constant flow, suitable for installations on distribution facilities. To optimize the performance and the time-life of the air-operated pumps, we advise to use filtered and lubricated air.

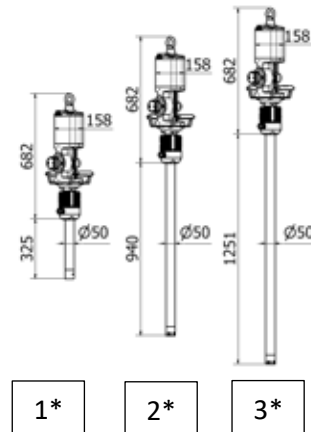
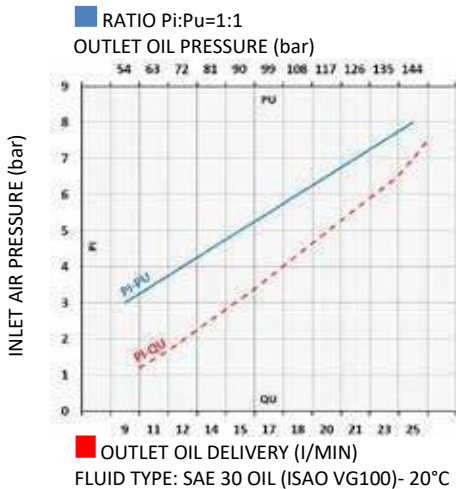

GENERAL TECHNICAL FEATURES				
Part Number		0400724 (1*)	0400725 (2*)	0400726 (3*)
Compression ratio		18:1	18:1	18:1
Max air pressure	bar	8	8	8
Max outlet pressure	bar	144	144	144
Air consumption @8 bar	m ³ /min	2,90	2,90	2,90
Air inlet connection	BSP	F 1/2" G	F 1/2" G	F 1/2" G
Fluid outlet connection	BSP	M 3/4" G	M 3/4" G	M 3/4" G
Fluid delivery @8 bar	l/min	25	25	25
Noise	dB	80	80	80
Shank diameter	mm	50	50	50
Shank length	mm	Modular F 1"	940	1250
For drums	l		180-220	750-1500

FEATURES

- Air-operated oil pump
- R = 20:1 Double-acting
- Working pressure: up to 8 bar
- For wall-fixing or fixed positions
- Polyurethane seals

**IPO INDUSTRIAL OIL PUMPS
R = 20:1 DELIVERY = 60 l/min**

These pumps are advised for the transfer of low-high viscosity oil and similar fluids for medium-long distances. The delivery capacity of a pump varies according to particular applications and combinations. The operating pressure may vary between a minimum of 3 bar and a maximum of 8 bar.

The double-acting guarantees the delivery of a continuous and constant flow, suitable for installations on distribution facilities. To optimize the performance and the time-life of the air-operated pumps, we advise to use filtered and lubricated air.

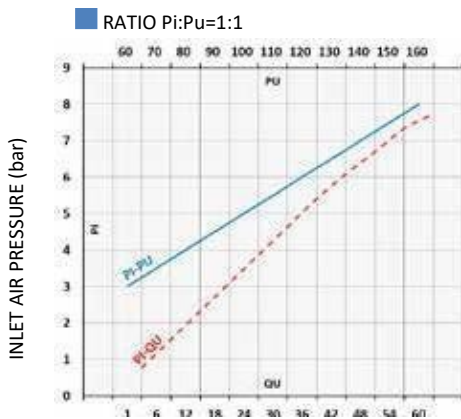

■ OUTLET OIL DELIVERY (l/MIN)
FLUID TYPE: SAE 30 OIL (ISAO VG100)- 20°C

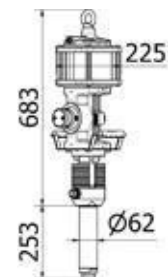

1*

BARREL PUMP AIR

GENERAL TECHNICAL FEATURES		
Part Number		0400729 (1*)
Compression ratio		20:1
Max air pressure	bar	8
Max outlet pressure	bar	160
Air consumption @8 bar	l/min	3,5
Air inlet connection	BSP	F 1/2" G
Oil outlet connection	BSP	M 3/4" G
Oil delivery @8 bar	l/min	60
Noise	dB	80
Shank diameter	mm	62
Shank length	mm	Modular F1"

IPO INDUSTRIAL AIR-OPERATED OIL PUMPS R = 6:1 FOR OIL AND SIMILAR FLUIDS



FEATURES

- Air-operated industrial disjoint pump for oil, lubricants and similar fluids
- R = 6:1 Double-acting
- High Delivery
- Working pressure: up to 8 bar
- For wall-fixing or fixed positions
- Polyurethane/viton seals

IPO INDUSTRIAL OIL PUMPS R = 6:1 DELIVERY = 80 l/min

Automatic engine body and shank kit are divided in order to avoid that the fluid enters directly in contact with motor body.

These pumps are advised for the transfer of oil and industrial fluids for medium-long distances, guarantee high performance as per delivery capacity (l/min) and also for working pressure.

The delivery capacity of a pump varies according to particular applications and combinations.

The operating pressure may vary between a minimum of 3 bar and a maximum of 8 bar. The double-acting guarantees the delivery of a continuous and constant flow, suitable for installations on distribution facilities.

To optimize the performance and the time-life of the air-operated pumps, we advise to use filtered and lubricated air.

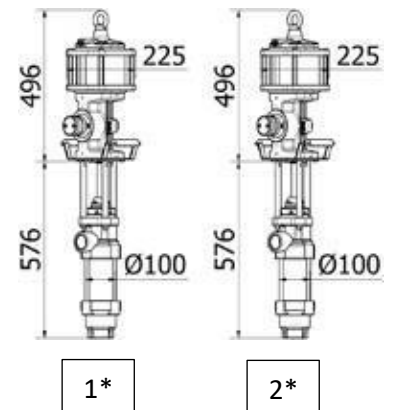
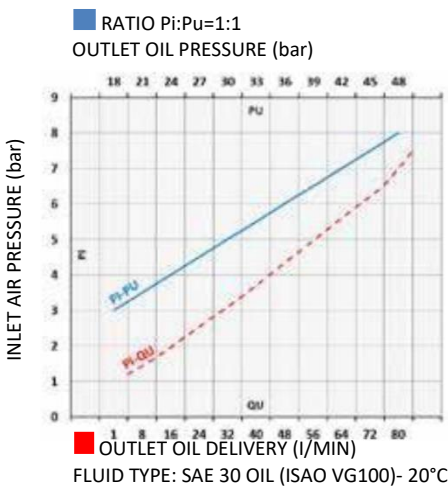

GENERAL TECHNICAL FEATURES			
Part Number		0400727 (1*)	0400728 (2*)
Compression ratio		6:1	6:1
Max air pressure	bar	8	8
Max outlet pressure	bar	48	48
Air consumption @8 bar	m ³ /min	3,50	3,50
Air inlet connection	BSP	F 1/2" G	F 1/2" G
Fluid outlet connection	BSP	F 1.1/2" G	F 1.1/2" G
Fluid delivery @8 bar	l/min	80	80
Noise	dB	80	80
Shank diameter	mm	100	100
Shank length	mm	Modular F 2"	Modular F 2"

C2325PE WK 30/23

DropsA products can be purchased at DropsA branches and authorised distributors. Go to www.dropsa.com/contact or write to sales@dropsa.com

Distributor info: